

APPROXIMATE WEIGHTS

FRAME 115 ± 12 LBS.
COVER 50 ± 3 LBS.
TOTAL 165 ± 15 LBS.

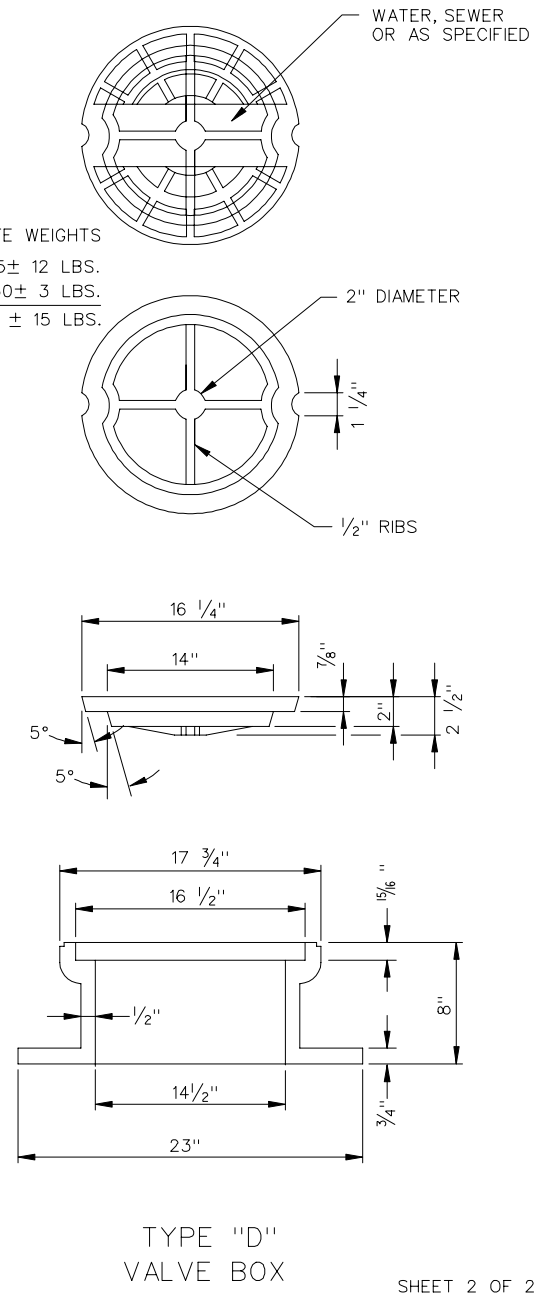

VALVE BOX AND VALVE MANHOLE
WATER AND SANITARY SEWER FACILITIES