

MB-3

1/2" (+1/4") CHAMFER ALL CORNERS

ALL CONCRETE SHALL BE CLASS A3.

3/4" HOLES TO BE CAST IN POST.

5/8" X 26" BOLT

6" X 8" X 1'-2" TREATED PINE BLOCK OR RECYCLED MATERIAL

4 #4 DEFORMED REINF. BARS 4" LESS THAN HEIGHT OF POST

CHAMFER MAY BE EXTENDED ENTIRE LENGTH OF POST AT THE OPTION OF THE FABRICATOR.

DIMENSIONS SHOWN IN PARENTHESIS INDICATE ACCEPTABLE TOLERANCES.

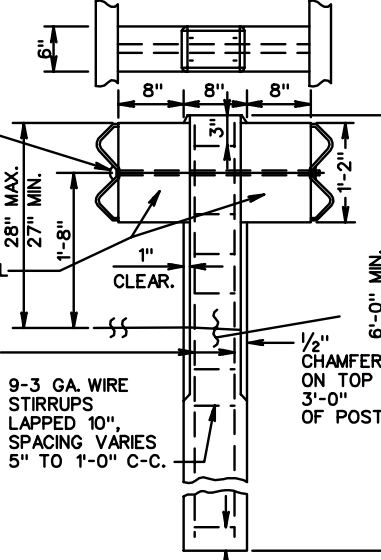

CONCRETE POST

POST MAY BE HOT ROLLED OR WELDED

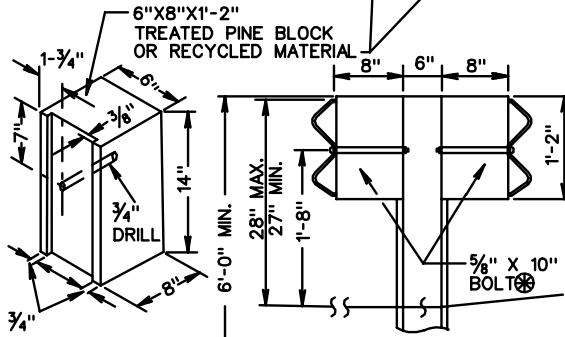

STEEL POST

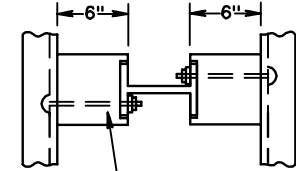

BLOCKOUT FOR MAINTENANCE REPAIR ONLY

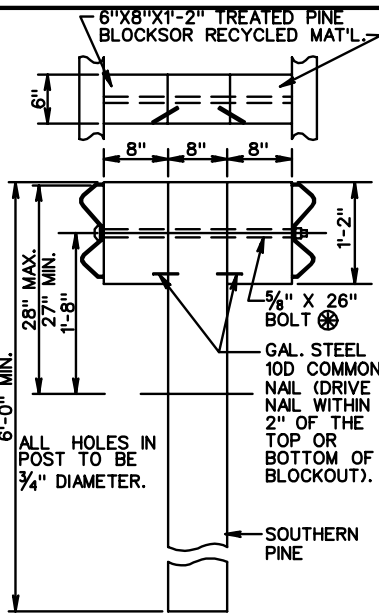

6X8 WOOD POST

NOTES:

STANDARD MB-3 POST SPACING IS 6'-3".

FOR DETAILS OF RAIL ELEMENT, RAIL SPLICE JOINT, W BEAM BACK UP PLATE, AND ASSOCIATED HARDWARE SEE SHEET NO. 501.01.

ALTERNATE TYPE POSTS AND BLOCKOUTS MAY BE INTERCHANGED ON ANY ONE PROJECT WITH THE RESTRICTION THAT THE SAME TYPE OF POST AND BLOCKOUT MUST BE USED IN ANY SINGLE RUN OF MEDIAN BARRIER.

ALL BOLTS, NUTS, WASHERS, STEEL POSTS, BENT PLATE POST, AND BLOCKOUTS ARE TO BE GALVANIZED.

THE GUARDRAIL AND MEDIAN BARRIER COMPONENTS DEPICTED IN A.R.T.B.A. TECHNICAL BULLETIN NUMBER 268B MAY BE SUBSTITUTED IF INTERCHANGEABLE WITH THE STANDARDS FOR GUARDRAIL (GR) OR MEDIAN BARRIER (MB) AND APPROVED BY THE ENGINEER.

⊗ STANDARD WASHERS ARE TO BE USED ON LAST 50' OF RUN OFF END.

DESIGN SPEED	FLARE RATES		
	INSIDE SHY LINE	FLARE RATE	BEYOND SHY LINE
MPH	SHY LINE LS	FLARE RATE	FLARE RATE
70	10'	30:1	15:1 *
60	8'	26:1	13:1 *
50	6.5'	21:1	11:1 *
40	5'	17:1	9:1 *
30	3.5'	13:1	7:1 *

\* SUGGESTED MAXIMUM FLARE RATE FOR SEMI-RIGID BARRIER SYSTEMS.

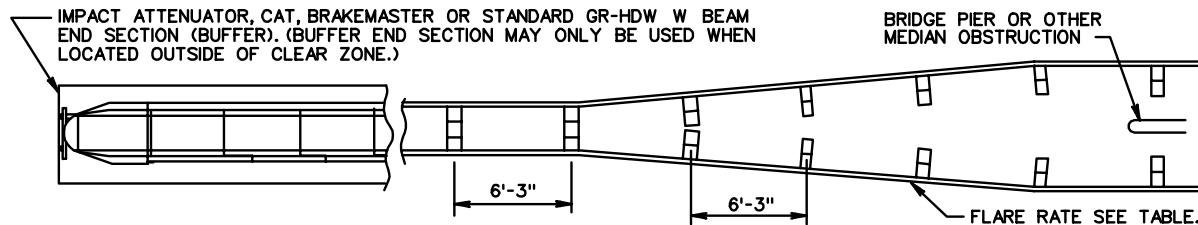

METHOD OF TREATMENT AT BRIDGE PIER OR MEDIAN OBSTRUCTION

BLOCKED-OUT W BEAM MEDIAN BARRIER

VIRGINIA DEPARTMENT OF TRANSPORTATION

SPECIFICATION REFERENCE

221  
505